

WIRING DIAGRAMS

INTERNAL WIRING

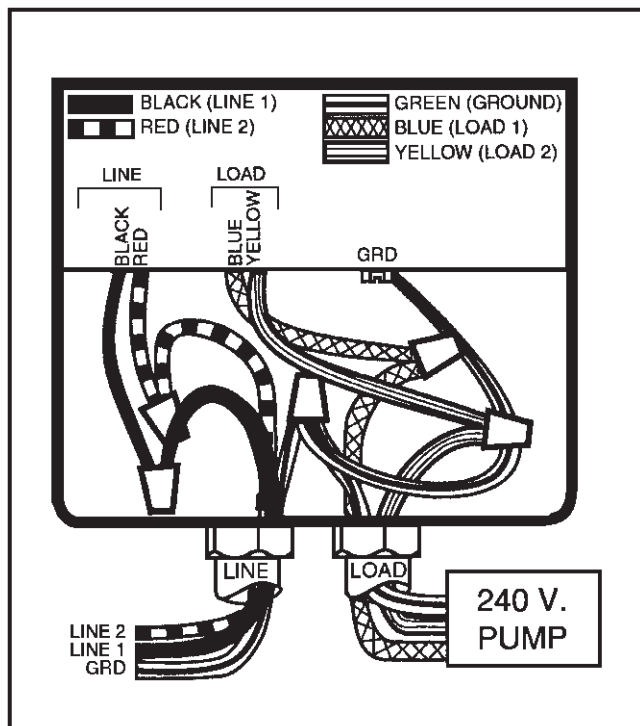
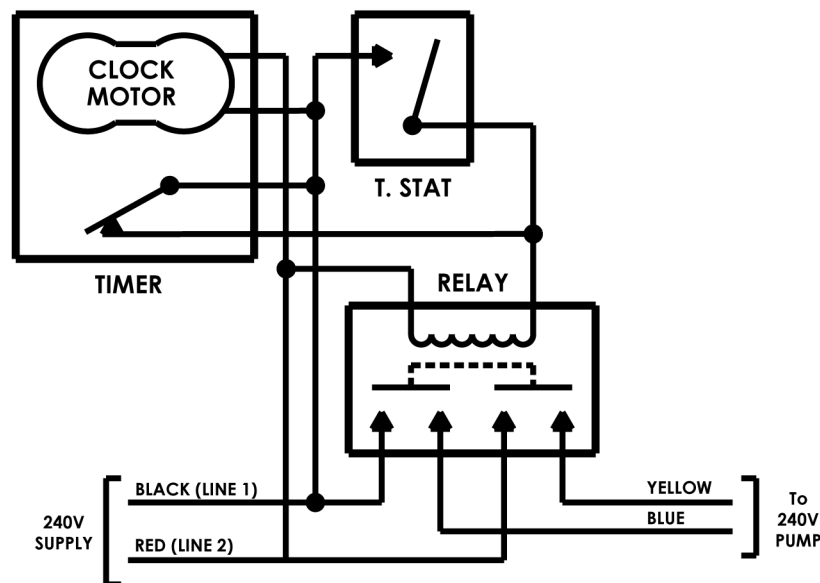

LIMITED ONE YEAR WARRANTY

If within one (1) year from the date of purchase, this product fails due to a defect in workmanship, Intermatic Incorporated will repair or replace it, at its sole option, free of charge. This warranty is extended to the original household purchaser only and is not transferable. This warranty does not apply to: (a) damage to units caused by accident, dropping, or abuse in handling, acts of God or any negligent use; (b) units which have been subject to unauthorized repair, opened, taken apart or otherwise modified; (c) units not used in accordance with instructions; (d) damages exceeding the cost of the product; (e) sealed lamps and/or lamp bulbs, LED's and batteries; (f) the finish on any portion of the product, such as surface and/or weathering, as this is considered normal wear and tear, (g) transit damage, initial installation costs, removal costs, or reinstallation costs.

INTERMATIC INCORPORATED WILL NOT BE LIABLE FOR INCIDENTAL OR CONSEQUENTIAL DAMAGES. SOME STATES DO NOT ALLOW THE EXCLUSION OR LIMITATION OF INCIDENTAL OR CONSEQUENTIAL DAMAGES, SO THE ABOVE LIMITATION OR EXCLUSION MAY NOT APPLY TO YOU. THIS WARRANTY IS IN LIEU OF ALL OTHER EXPRESS OR IMPLIED WARRANTIES. ALL IMPLIED WARRANTIES, INCLUDING THE WARRANTY OF MERCHANTABILITY AND THE WARRANTY OF FITNESS FOR A PARTICULAR PURPOSE, ARE HEREBY MODIFIED TO EXIST ONLY AS CONTAINED IN THIS LIMITED WARRANTY, AND SHALL BE OF THE SAME DURATION AS THE WARRANTY PERIOD STATED ABOVE. SOME STATES DO NOT ALLOW LIMITATIONS ON THE DURATION OF AN IMPLIED WARRANTY, SO THE ABOVE LIMITATION MAY NOT APPLY TO YOU.

This warranty service is available by either (a) returning the product to the dealer from whom the unit was purchased, or (b) mailing the product, along with proof of purchase, postage prepaid to the authorized service center listed below. This warranty is made by: Intermatic Incorporated/After Sales Service/7777 Winn Rd., Spring Grove, Illinois 60081-9698/815/675/7000 <http://www.intermatic.com> Please be sure to wrap the product securely to avoid shipping damage.

INTERMATIC® PF1100 SERIES

FREEZE PROTECTION CONTROLS

INSTALLATION OPERATION & SERVICE MANUAL

Model: PF1102T TIME CONTROL WITH FREEZE PROTECTION
IN RAINPROOF (TYPE 3R) ENCLOSURE

Model: PF1102MT TIME CONTROL MECHANISM ONLY
WITH FREEZE PROTECTION

SUITABLE FOR POOL/SPA EQUIPMENT CONTROL

INPUT VOLTAGE: 240 VOLT - 60 HZ.

ELECTRICAL RATING: 1.5 HP - 120 VOLT AC, 3 HP - 240 VOLT AC.

⚠ DANGER

Risk of drowning!

*Do not permit unsupervised children to use pool or spa.
Close supervision of children required at all times.*

⚠ WARNING

Risk of electric shock!

*Test ground fault protection regularly. If it fails, do not use Pool or Spa. Contact qualified service professional for help.
Do not use this control as a power disconnect, it could turn ON unexpectedly.
Disconnect electricity at the main Panel before servicing this control or the equipment(s) connected to it.*

This Time Control with Freeze Protection is designed to automatically control as well as protect the Pool/Spa equipment and plumbing against freeze damage. The Control, if wired according to instructions, turns ON/OFF the Filter Pump on a daily schedule and also turns ON the Filter Pump when the air temperature (where this Control is located) drops below the temperature set by the thermostat dial (between 33°F and 42°F). Nevertheless, the Control is not intended to be a substitute for insulation, coverings or maintenance.

It is self-contained in an indoor-outdoor, beige rainproof enclosure and designed to operate on 240 Volt, 60 cycle only.

Model PF1102MT is a mechanism only, functions just like Model PF1102T and fits (snaps into) any Intermatic Pool Panel, Models T10000R, T30000R or T40000R Series.



Because of our commitment to continuing research and improvements, Intermatic Incorporated reserves the right to make changes, without notice, in the specifications and material contained herein and shall not be responsible for any damages, direct or consequential, caused by reliance on the material presented.

! CAUTION

Risk of injury or property damage!

Do not install or operate this equipment and other associated equipment without basic safety precautions.

Read and follow the safety instructions listed below and other basic safety precautions before installation or operation of this control and other associated equipment.

1. *This control must be installed by a qualified person, according to the national and local electrical codes.*
2. *Install this control not less than 5 feet (3 meters in Canada) from inside edge of pool and 1 foot (30cm) above ground.*
3. *USE COPPER CONDUCTORS ONLY rated 75°C minimum.*
4. *Do not exceed maximum ratings of individual components, wiring devices and current carrying capacity of conductors.*
5. *For control grounding, bonding, installing and the wiring of underwater lights, refer to Article 680 of the National Electrical Code or Article 68 of the Canadian Electrical Code.*
6. *The control should not operate any equipment which would cause bodily injury or property damage should it be activated unexpectedly.*

INSTALLATION

1. Select the proper outdoor location for the Control and prepare the necessary conduit run(s) required by the installation layout.
2. Hang enclosure on a flat vertical surface or other support, using hardware suitable for the purpose.
3. Properly terminate conduits at both ends and pull-in the conductors (Min. 75°C Rated) as specified by the installation layout.
4. Select the appropriate wiring diagram (120V or 240V installation) on page 4 of this manual and make LINE and LOAD (Pump) connections as shown. First identify each lead by color. The LINE connections for 240 Volt supply are Black and Red. To operate the clock motor and relay coil, you also have to connect the NEUTRAL to the White lead. NOTE: If the 240 Volt supply is GFCI protected - Stop. This is not the right control for such applications. Use Model PF1102T instead. Otherwise connect pump to Blue and Yellow leads. Make sure the installation is properly grounded.
5. If the Control is installed in location where it is exposed to direct sun most of the day, extend 8 inches of the copper capillary tube of the

thermostat into an open ended (plastic or metal) conduit, about 10 inches long, installed at bottom of the enclosure. Handle capillary tube with care!

6. TEST INSTALLATION:

- a. Turn thermostat dial to its lowest setting and place crushed ice (in plastic bag) inside capillary coil of Thermostat.
- b. Turn power ON to Control, wait one minute then slowly turn thermostat dial counter clockwise until Filter Pump starts.
- c. Turn power OFF to Control, remove ice, check wiring, reinstall front plate.
- d. Turn power ON to Control and set Timer and the Thermostat, see OPERATION instructions on page 3.

INSTALLATION - MODEL PF1103MT

1. Install mechanism in any Intermatic Pool Panel with only one Time Switch by snapping it into the unused mounting bracket, furnished with the Panel.

SETTING / OPERATING INSTRUCTIONS

TO SET FILTER TIMER, follow instructions on page 3. The length of the daily filtration/heating cycle depends on many variables such as size, shape, and geographic location of the pool, water chemistry, type of pool equipment, usage and season of year. If not sure, contact your local pool service professional for advice.

TO SET THERMOSTAT, turn dial to desired temperature between 33°F and 42°F. Remember, many variables, such as the location of this Control, the location of the pool or spa, the location and insulation of the plumbing, etc., must be considered before selecting the "turn ON" temperature of the Filter Pump. Your local pool service professional is the best source of information. The Thermostat is factory set to turn OFF the Filter Pump when the ambient temperature rises 5° F above its set point.

OPERATION (CONT.)

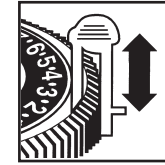

Figure 1

1. Insert ON (green) and OFF (red) trippers into dial at desired ON and OFF times (Fig. 1).

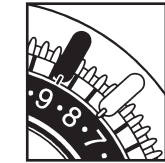

Figure 2

2. Be sure trippers are firmly pressed against dial surface and at least one space is left between ON and OFF trippers (Fig. 2).



Figure 3

3. Turn dial clockwise one or more revolutions until correct time of day is next to arrow in center of dial (Fig. 3).

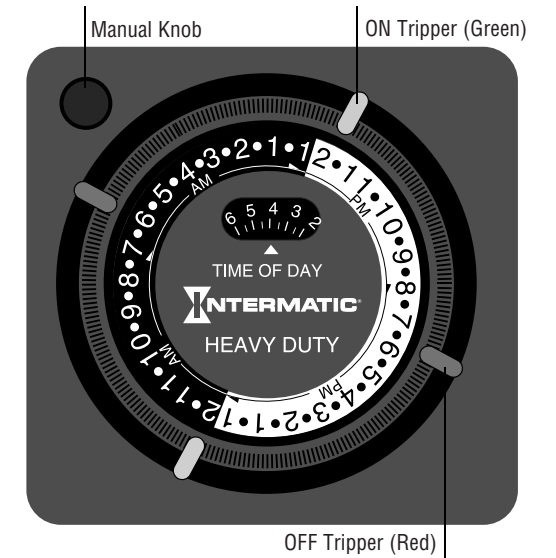

1. The knob in the upper left corner of timer is for operating the Filter pump manually when needed. By turning it COUNTERCLOCKWISE, it will start or stop the filtering/heating cycle ahead of the scheduled start/stop time. Automatic operation will resume with the next scheduled cycle.
2. Timer comes with two sets of trippers, allowing the choice of two cycles per day. If only one cycle is needed, the extra trippers may be stored on the dial by placing SAME color trippers next to each other.

3. To suspend automatic operation, remove red and green trippers from Dial and Store them in a convenient place.
4. Additional trippers can be obtained by contracting an Intermatic distributor or Intermatic Consumer Service at (815-675-7000 and asking for 156PB10398A tripper kit (2 ON and 2 OFF trippers.)

TROUBLESHOOTING

SYMPTOM	CAUSE(S)	CORRECTIVE ACTION
1. Timer will not keep time	No trippers on dial Trippers are not installed properly	Install trippers Re-install trippers on dial
2. Timer dial is not turning	Breaker OFF Timer motor dead due to lightning	Turn ON Power Replace timer
3. Pump operates off schedule	Power failure earlier Breaker was OFF for some time	Reset timer Reset timer
4. Filter pump is ON at all timer	Timer contacts welded	Replace timer
5. Filter Pump will not start when temp. is below 32 deg.	Defective thermostat (see Test procedure) Defective relay Defective wiring	Replace t.stat Replace relay Check wiring